

SPECIFICATIONS

Technical code	F3GFE611A*CXXX	
Thermodynamic cycle	Diesel 4 stroke	
Air intake	TAA	
Arrangement	6L	
Bore x Stroke	mm	128 x 144
Total displacement	L	11.1
N° valves per cylinder	4	
Cooling	liquid	
Direction of rotation	CCW	
Compression ratio	16.5 : 1	
Rotation mass moment of inertia (without flywheel)	kgm ²	0.848
Standard flywheel inertia	kgm ²	1.44

FUEL SYSTEM

Injection system	Electronic Common Rail	
Upstream injectors fuel pressure	kPa (bar)	1700
Gas oil max intake temperature	°C	80° at fuel filter

AIR INTAKE

Max suggested intake restriction	kPa(bar)	6.0 (0.06)
Air flow at 100% load / rated speed	kg/h(m ³ /h)	1710 (1610)
Turbocharging pressure at full load/rated speed	kPa(bar)	180 (1.780)
Turbocharging air max temperature (engine inlet)	°C	45
Heat rejected to intercooler at maximum power	kW(kcal/h)	71 (61.1)
Intercooler system max pressure drop	kPa(bar)	10 (0,1)

EXHAUST SYSTEM

Max allowable backpressure	kPa(bar)	25 (0.250)
Max exhaust temperature at full load/rated speed	°C	570
Exhaust flow at max output	kg/h	1800

C11 ENT VI

353 kW @ 1900 rpm - 2250 Nm @ 1050 rpm

EURO VI

LUBRICATION SYSTEM

Minimum oil pressure at idle	kPa(bar)	150 (1.5)
Max oil pressure at max rating	kPa(bar)	500 (5.0)
Max oil temperature at full load/rated speed	°C	125
Engine angularity limits continuous operation:		
max front up and front down	0/360°	17
max left hand and right hand	0/360°	17
Total system capacity including pipes, filters, etc.	liters	28

COOLING SYSTEM

Coolant capacity (engine only)	liters	10
Water pump flow at rated speed	m ³ /h	30
Heat to reject by heat exchanger at max power	kW	143
Modulating range thermostat	°C	84° ÷ 94°
Cooling liquid max temperature	°C	106
Min/max inner pressure in the cooling circuit	kPa(bar)	n.d.
External cooling system max pressure drop	kPa(bar)	20 (0.20)

ELECTRICAL SYSTEM

Voltage	V	24
---------	---	----

Dimensions



Std. application used as a reference

C11 ENT VI

353 kW @ 1900 rpm - 2250 Nm @ 1050 rpm
EURO VI

PERFORMANCE

Maximum rating [*]	kW(HP)	353 (480)
At speed	rpm	1900
Maximum torque	Nm(kgm)	2250 (229)
At speed	rpm	1050
Engine brake power	kW	372
At speed	rpm	2400
Maximum no load governed speed at max rating	rpm	2320 ± 50
Minimum idling speed	rpm	550 ± 50
Mean piston speed at rated speed	m/s	9.12
BMEP at max torque	bar	25.4
Available certifications	EC 595/2009 - EC 582/2011 - EC 64/2012	
Specific fuel consumption at max power	g/kWh	196
Specific fuel consumption at max torque	g/kWh	194
Oil consumption at max rating	% fuel consumption	0.09
Noise at max rating (ISO 3744)	dB(A)	n.a.
Minimum starting temperature without auxiliaries	°C	-15
Oil and oil filter maintenance interval for replacement [**]	Km (up to)	150000
Dry weight (standard configuration for truck version without cooling)	kg	1220

FOR INFORMATION ON THE AVAILABLE RATINGS NOT LISTED IN THIS DOCUMENT PLEASE CONTACT THE FPT SALES NETWORK.

[*] Power at flywheel according to 97/68 EC (without fan), after 50 hours running, 3% tolerance, fuel Diesel EN 590.

[**] Oil type: ACEA E6, SAE 5W30 low saps

Test conditions: ISO 3046/1, 25 °C air temperature, 100 kPa atmospheric pressure, 30 % relative humidity - Applicable also to DIN 6271, BS 5514, SAE J1349 Standards.

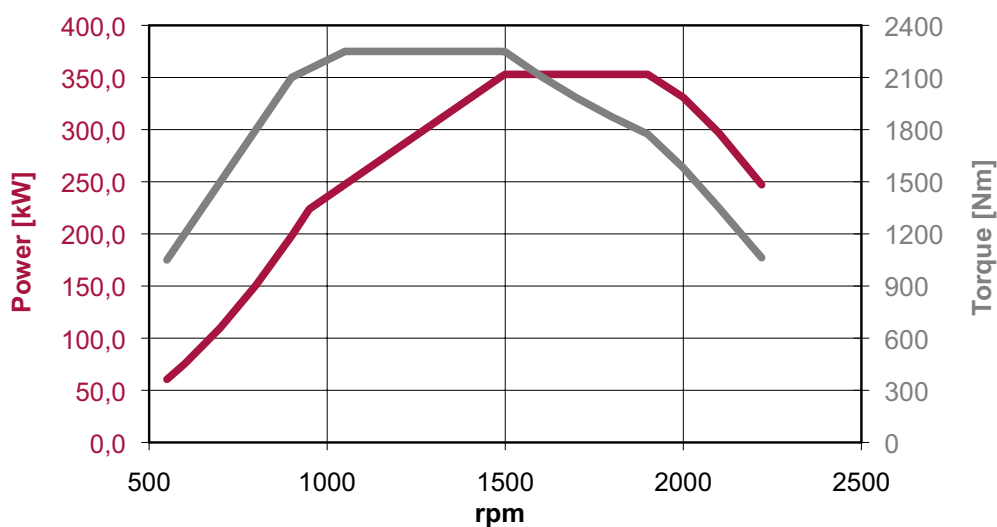

C11 ENT VI

353 kW @ 1900 rpm - 2250 Nm @ 1050 rpm

EURO VI

STANDARD CONFIGURATION

Flywheel housing	type	SAE 1 - aluminium
Flywheel size	inch	17"
Intake manifold location		middle high / right side
Exhaust manifold location middle high		middle high / left side / back
Turbocharger		Electronic Variable Geometry Turbocharger with exhaust flap
Turbocharger location		center / left side
Fan transmission ratio		1.3 : 1
Distance between fan - crankshaft centers	mm	x = -20 ; y = 225
Fuel filter		single cartridge - left side
Oil filter		single cartridge - right side
Oil sump		suspended sheet steel/front sump
Oil vapours blow-by circuit		close case ventilation
Oil heat exchanger		integrated into the block
Oil filler		on valve cover
Starter		24V - 5.5 kW
Alternator		24V - 90A
Air Compressor	cm ³	352 - 630
Hydraulic steering pump - available versions	liters/min	16 - 20 - 25
Maximum torque available from crankshaft pulley		800 Nm
Engine stop device		by electronic control unit
Wiring harness		interface wiring loom with accessories
Painting	colour	grey

NOT INCLUDED IN THE STANDARD CONFIGURATION

Power take off - transmission ratio		1 : 1.14
PTO - maximum available torque from rear gear		800 Nm
Battery - minimum capacity recommended [*]		24 V - 355 Ah
Battery - minimum cold cranking capacity recommended [*]		24 V - 511 Ah

[*] at -25°C with SAE 5W30 oil

LEGEND:

n.a. = not applicable

n.av. = not available

AFTERTREATMENT SYSTEM

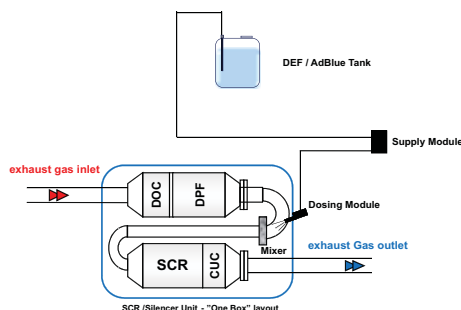

HI-eSCR (High Efficiency SCR)

Main components - Functional Scheme

- Supply Module
- Dosing Module
- SCR Catalyst with integrated CUC*
- DOC**
- DEF***/AdBlue Tank
- DPF****

*CUC: Clean Up Catalyst

**DOC: Diesel Oxidation Catalyst

***DEF: Diesel Exhaust Fluid

****DPF: Diesel Particulate Filter

FPT OFFERS THE WIDEST AVAILABILITY OF ENGINE BUILD OPTIONS TO CUSTOMER SPECIFIC REQUIREMENTS WITHIN THE ENGINE SUPPLY.

TO FIND OUT MORE ABOUT THE CONFIGURATIONS AND ACCESSORIES WHICH ARE AVAILABLE, CONTACT THE FPT SALES NETWORK.